

**ISATRONIC**

Cal 127 / 1301

 **SWISS MADE**

7 3/4 '''

17.20 mm

H. 1.40

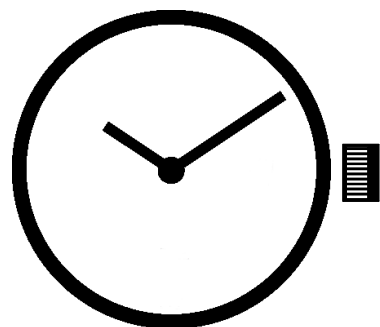

DATASHEET

SLIM  
2 HANDS

**ISASWISS**  
WATCH MECHANISMS

In conformity with RoHS standard

Doc. n° 0312021 - H Up date . 25/04/2013 - Page 1

**Caractéristiques :**

Mouvement 2 aiguilles.  
 Mouvement électronique à quartz, 8 rubis. Moteur rotatif pas à pas, 3 pas par minute.  
 Tige 2 positions.

**Characteristics :**

Movement with 2 hands.  
 Electronic quartz movement, 8 jewels. Rotary stepping motor, 3 steps per minute.  
 2 handsetting positions.

**Kennzeichnungen :**

2 Zeiger Werk .  
 Elektronisches Quarzwerk, 8 Steine. Schrittschaltmotor, 3 Schritten pro Minute.  
 2 Stellwellenpositionen.

Critères Criteria Kriterium	Conditions Conditions Bedingungen	Min.	Typ.	Max.	Unités Units Einheit
Consommation - Current consumption Stromaufnahme	U=1.55V T=25°C		0.35		µA
Marche instantanée - Instantaneous rate Momentaner Gang	U=1.55V T=25°C	-0.3 (-9)		+0.6 (+18)	s/jour s/day s/Tag (s/mois s/month s/Monat)
Température de fonctionnement Operating temperature Betriebstemperatur		0		50	°C
Résistance aux champs magnétiques Resistance to magnetic fields Magnetfeldabschirmung			1500 (18.8)		A/m (Oe)

Qté Qty Menge	Désignation Designation Bezeichnung	Type Model Typ	Tension Voltage Spannung	Code Code Kode	Capacité Capacity Kapazität	Autonomie théorique Theoretical autonomy Theoretische Gangreserve
1	Pile Battery Batterie 7.90 x 1.45	SR 714 SW	1.55 V	341	15 mAh	60 Mois Months Monate

## CAGE / FRAME

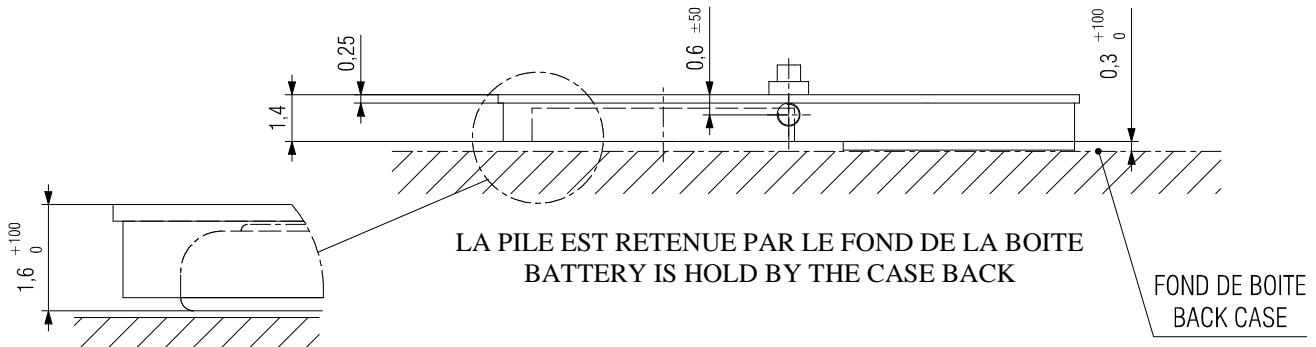

CLEFS DE FIXE OU CERCLE D'EMBOÏTAGE  
CASE SCREWS OR CASING RING  
AUTRES FIXATIONS POSSIBLES  
OTHER FASTENINGS POSSIBLE

EMBOITAGE PAR LE VERRE / TOP CASING  
Coupe / Cut A - A

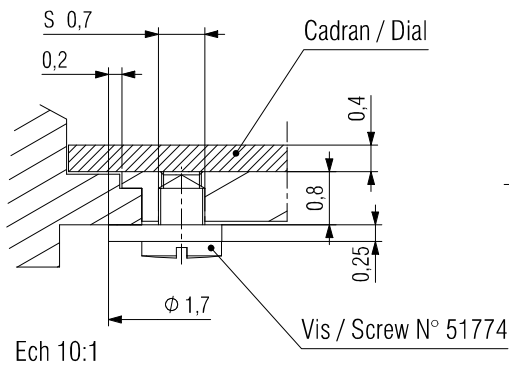

EMBOITAGE PAR LE FOND / BOTTOM CASING  
Coupe / Cut A-A

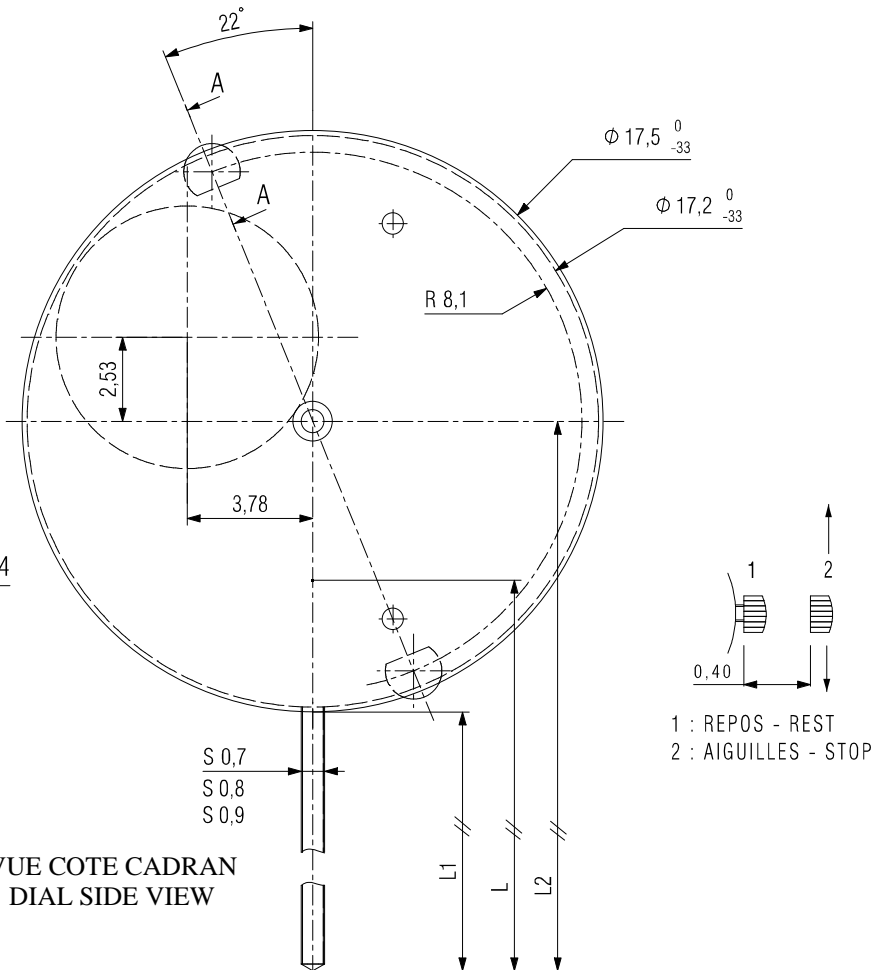
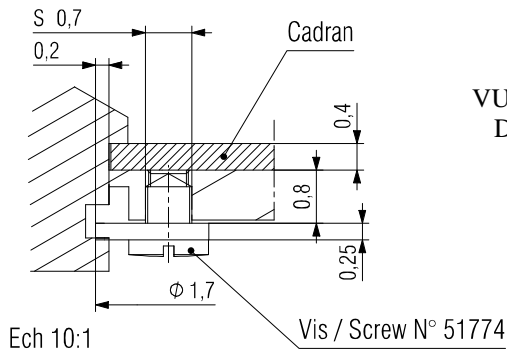

Tige en position repos / Stem in rest position	L	L1	L2
Standard / Standard	17.96 ±100	11.65	20.4
Longue / Long (S 0.7)	19.96 ±100	13.65	22.4

DIMENSIONS IN mm. - TOLERANCES IN  $\mu$ m.

## CADRAN / DIAL

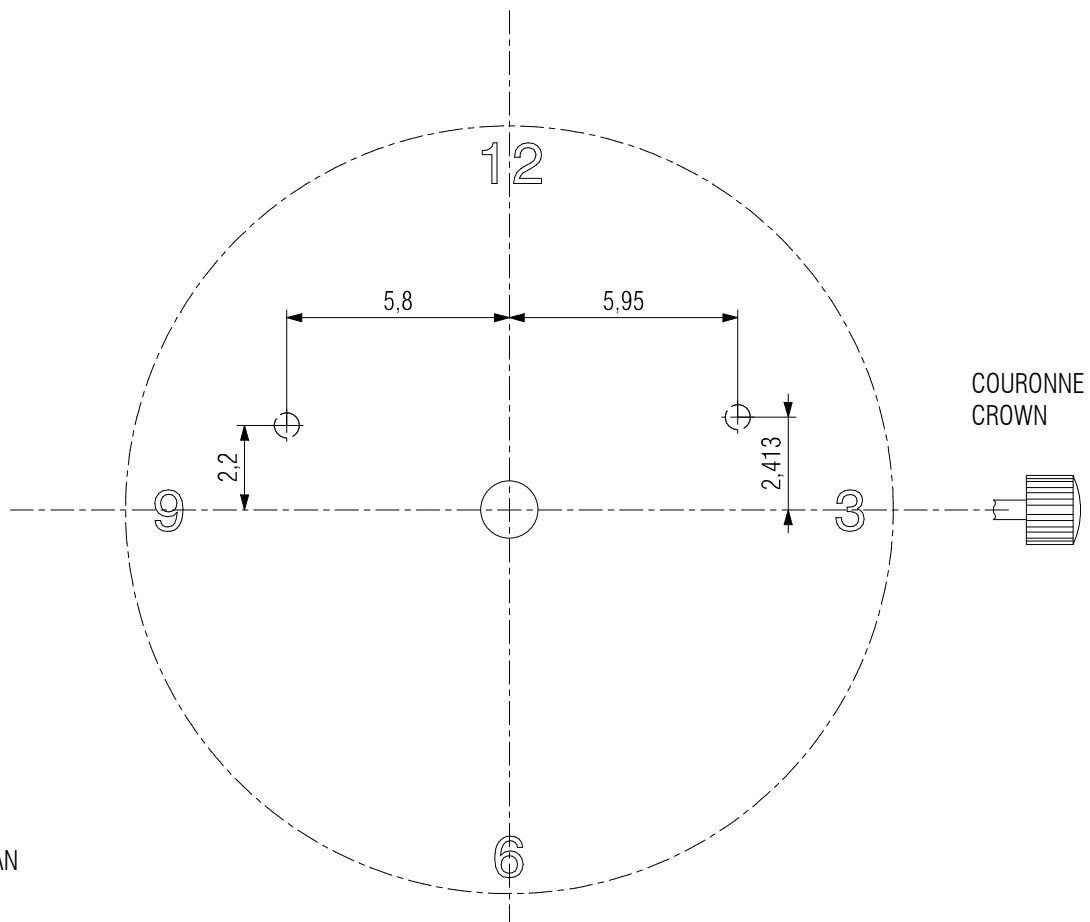
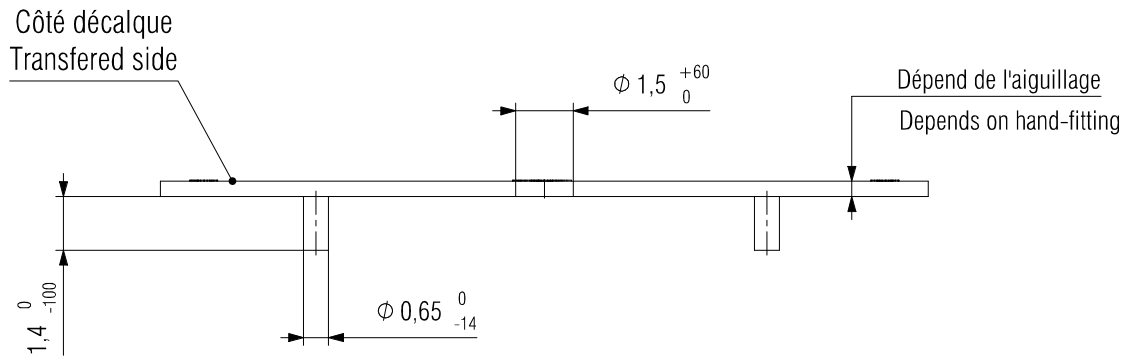

VUE COTE CADRAN  
DIAL SIDE VIEW

DIMENSIONS IN mm. - TOLERANCES IN  $\mu\text{m}$ .

In conformity with RoHS standard

Doc. n° 0312021 - H Up date . 25/04/2013 - Page 4

## AIGUILLAGE / HAND-FITTING

AUTRES AIGUILLAGES SUR DEMANDE  
OTHER HAND-FITTING ON REQUEST

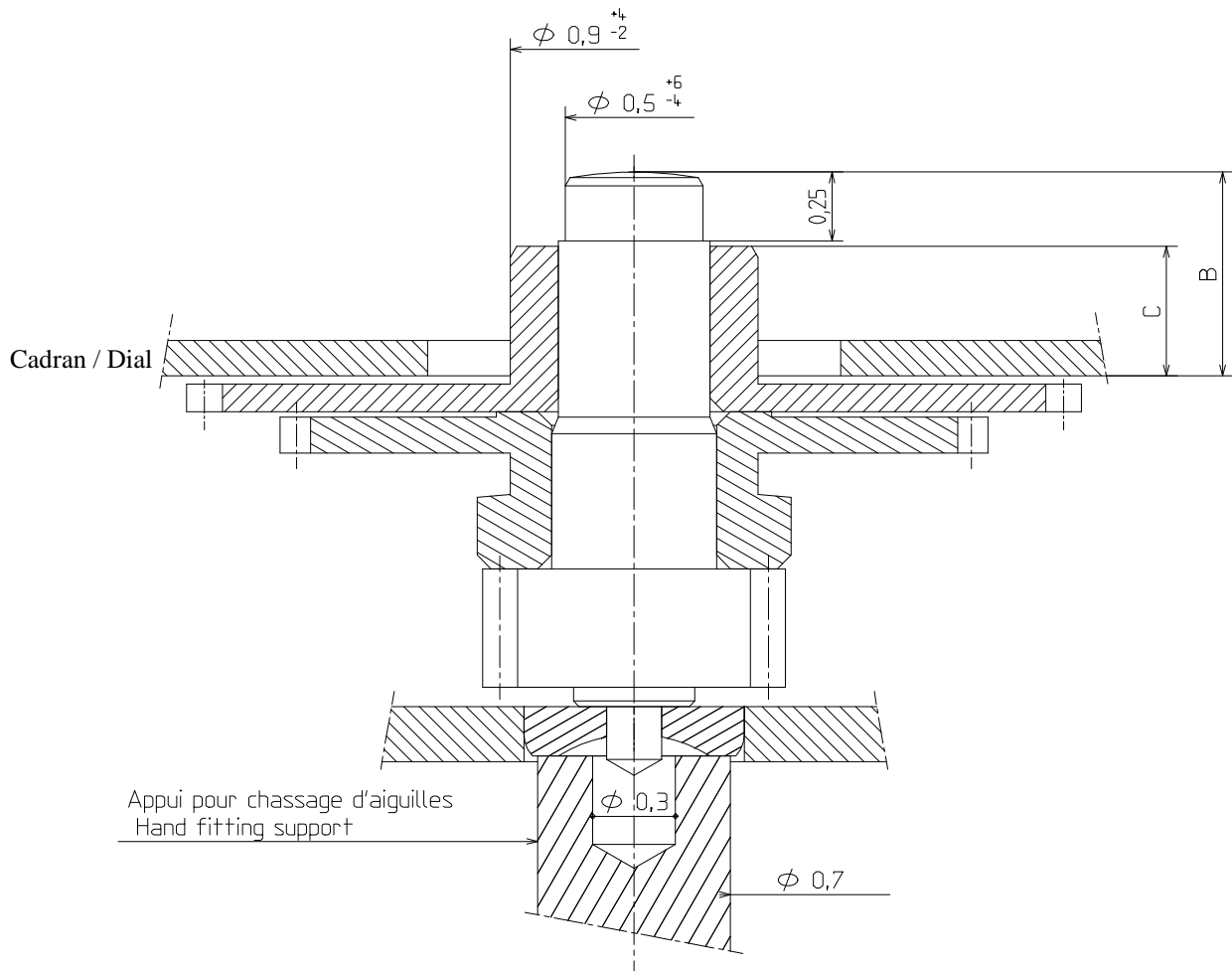

AIGUILLAGE / HAND-FITTING	Dépassement / Height over dial seat		Epaisseur cadran / Dial Thickness
	B	C	
	Chaussée / Cannon pinion	Roue des heures / Hour wheel	
N°1 réduit / reduced	0.87	0.60	0.30 maxi
N°2	1.17	0.90	0.40 maxi
N°3	1.37	1.10	0.60 maxi
Hauteur tube / Pipe height	0.25	0.50	-
<b>CHOCS 450 g / 450 g SHOCKS</b>	<b>Balourd / Unbalance</b>		<b>FORCE DE CHASSAGE / PRESS-IN- FORCE</b>
Aiguille des minutes - Minute Hand	≤ 0.5 µNm		≤ 25 N

DIMENSIONS IN mm. - TOLERANCES IN µm.

In conformity with RoHS standard

Doc. n° 0312021 - H Up date . 25/04/2013 - Page 5